

Marca/Modello	Rif. Originale	Codice	Disegno	Piatto	Fori	Interasse	Peso	Accessori
Machine brand name	Original code	Ref. Nr.	Draw	Plate	Holes	Center dist.	Weight	Accessories
Marke Maschine	Original-Code	Re. Nr.	Zeichnung	Platte	Locher	Achsenabstand	Gewicht	Zubehör
Marque de la machine	Code original	Ref. Nr.	Dessin	Plaque	Trous	Entraxe	Poids	Accessoires
							gr	

AGROROSSI - MAZZOTTI

Vomere a 6 fori	-	VOM03		105X8	13	146-210	2000	-
Vomere a 4 fori	-	VOM02		120x8	13	150-210	2400	-
VOMERE MB6 CANTIERI DX+SX	-	VOM59		120x6	13	150	1800	-
FLAGELLO DEFOGLIATORE	-	VOM16		50X5	20,5	-	570	-

BARIGELLI

LAMA PER BIFILA, PER MONOFILA TRAINATA PER MONOFILA SEMOVENTE DX+SX	-	VOM10		80X7	14,5	40	1000	-
VOMERE PER BIFILA DX+SX	-	VOM07		110X8	13	210	2450	-
VOMERE PER MONOFILA DX+SX	-	VOM08		100X8	13	210	2000	-
VOMERE B/6 PER SEI FILE DX+SX	-	VOM60		100X8	13	210	1850	-
VOMERE B/3 PER TRE FILE DX+SX	40301100	VOM48		110X8	13	210	2300	-
VOMERE B/6 TIPO NUOVO DX+SX	-	VOM61		-	13	175	2400	-

Marca/Modello	Rif. Originale	Codice	Disegno	Piatto	Fori	Interasse	Peso	Accessori
Machine brand name	Original code	Ref. Nr.	Draw	Plate	Holes	Center dist.	Weight	Accessories
Marke Maschine	Original-Code	Re. Nr.	Zeichnung	Platte	Locher	Achsenabstand	Gewicht	Zubehör
Marque de la machine	Code original	Ref. Nr.	Dessin	Plaque	Trous	Entraxe	Poids	Accessoires
							gr	

BARIGELLI

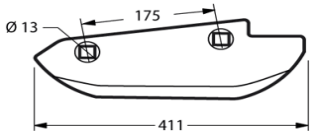
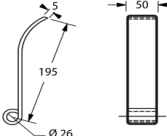
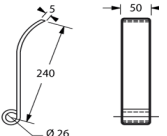
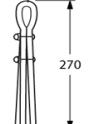
VOMERE B/6 TIPO NUOVO DX+SX	-	VOM62		-	13	175	2400	-
FLAGELLO B1/B2/B3	-	VOM11		50X5	26	-	600	-
FLAGELLO B2	-	VOM12		50X5	26	-	650	-
SPAZZOLA IN GOMMA TELATA E VULKOLLAN	-	VOM13		-	-	-	200	-

FONTANI

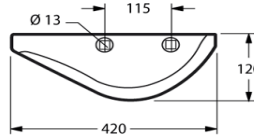
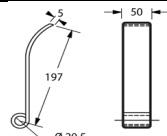
VOMERE DX+SX	-	VOM15		120X6	13	115	1500	-
FLAGELLO DEFOGLIATORE	-	VOM16		50X5	20,5	-	570	-

GUARESÌ

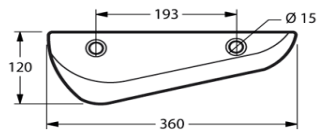
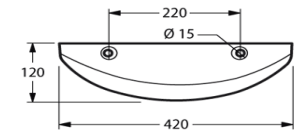
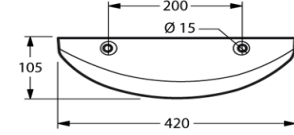
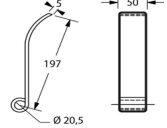
VOMERE PER MONFILA TRAINATA DX+SX	-	VOM18		120X8	15	193	2000	-
VOMERE PER BIFILA SEMOVENTE	-	VOM20		120X8	15	220	2400	-
VOMERE PER MONOFILA SEMOVENTE	-	VOM19		105X8	15	200	2000	-
FLAGELLO DEFOGLIATORE	-	VOM16		50X5	20,5	-	570	-

Marca/Modello	Rif. Originale	Codice	Disegno	Piatto	Fori	Interasse	Peso	Accessori
Machine brand name	Original code	Ref. Nr.	Draw	Plate	Holes	Center dist.	Weight	Accessories
Marke Maschine	Original-Code	Re. Nr.	Zeichnung	Platte	Locher	Achsenabstand	Gewicht	Zubehör
Marque de la machine	Code original	Ref. Nr.	Dessin	Plaque	Trous	Entraxe	Poids gr	Accessoires

GUARESÌ

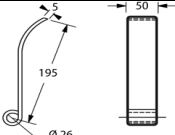
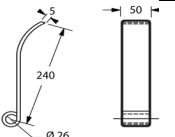
FLAGELLO B1/B2/B3	-	VOM11		50X5	26	-	600	-
FLAGELLO B2	-	VOM12		50X5	26	-	650	-

HOLMER

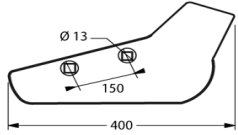
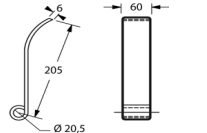
VOMERE SP. 8 DX+SX	-	VOM50		-	13	150	2400	-
FLAGELLO	111 000 1829	VOM51		60X6	20,5	-	800	-

ITALO - SVIZZERA

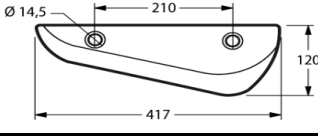
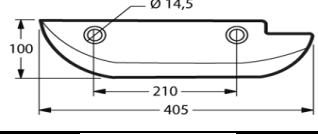
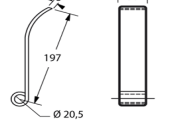
VOMERE MONOFILA DX+SX	-	VOM26		120X8	14,5	210	1920	-
VOMERE BIFILA DX+SX	-	VOM27		100X8	14,5	210	2000	-
FLAGELLO DEFOGLIATORE	-	VOM30		50X5	20,5	-	570	-

KLEINE

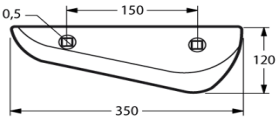
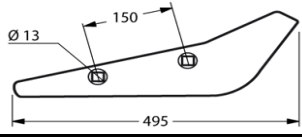
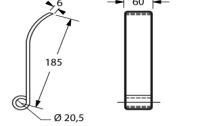
VOMERE DX+SX	-	VOM33		120X7	10,5	150	1700	-
VOMERE PER 6 FILE DX+SX SP. 7	-	VOM55		-	13	150	2000	-
DEFOGLIATORE	-	VOM56		60X6	20,5	-	700	-

Marca/Modello	Rif. Originale	Codice	Disegno	Piatto	Fori	Interasse	Peso	Accessori
Machine brand name	Original code	Ref. Nr.	Draw	Plate	Holes	Center dist.	Weight	Accessories
Marke Maschine	Original-Code	Re. Nr.	Zeichnung	Platte	Locher	Achsenabstand	Gewicht	Zubehör
Marque de la machine	Code original	Ref. Nr.	Dessin	Plaque	Trous	Entraxe	Poids gr	Accessoires

RIMECO

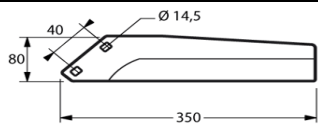
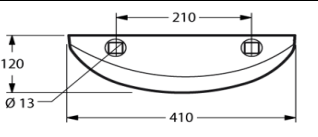
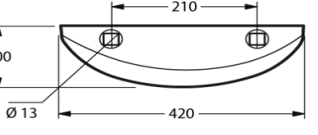
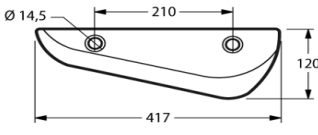
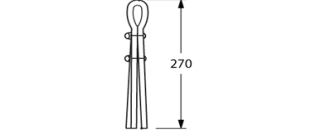
LAMA BIFILA DX+SX	-	VOM57		80X7	14,5	40	1000	-
VOMERE ALTO DX+SX	-	VOM36		120X8	13	210	2550	-
VOMERE MONOFILA DX+SX	-	VOM58		100X8	13	210	2000	-
VOMERE SEI FILE DX+SX	-	VOM26		120X8	14,5	210	1920	-
SPAZZOLA IN GOMMA TELATA E VULKOLLAN	-	VOM13		-	-	-	200	-

STACCHEZZINI

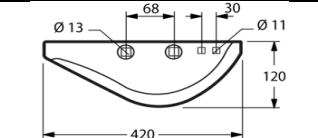
VOMERE DX+SX	-	VOM42		120X6	13	68	1500	-
--------------	---	-------	---	-------	----	----	------	---